

# Small Eagle Grinder / Shredder Technical Specifications

The Small Eagle grinder continues its legacy in the size reduction market with its robust design and proven history. These low-speed high-torque grinders are available in 25" thru 42" widths and are powered by 20 thru 50 HP electric motors. Full functioned touch-screen PLC controls provide all the necessary settings required to run any application. The small footprint allows for easy installation in tight buildings and mobile applications.

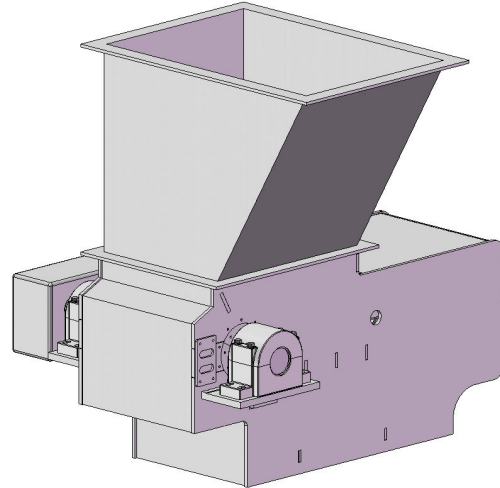

Specifications	25"	32"	42"
Motor (HP)	20 - 40 HP		40 - 50 HP
Rotor Dia (in)	10"		
Rotor Speed (RPM)	130 - 150 RPM		
Cutters (Hawksbill 40mm)	18 - 36	22 - 44	42 - 84
Cutters (Zoidal)	-	14 - 28 - 42	19 - 38 - 57
Ram Height (in)	7"		
Ram Hydraulic Motor (HP)	3 HP		5 HP
Hopper Opening (WxL) (in)	25" x 32"	32" x 40"	42" x 44"
Voltage	460V / 3 / 60		
Weight Approx. (tons)	2	2.5	3.5

Specifications, appearances, and dimensions are subject to change without notice.

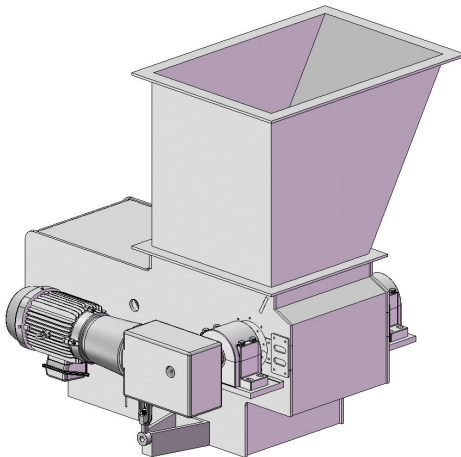

## Standard Features

- Solid Alloy Steel One-Piece Forged Rotor Limited Lifetime Warranty
- Oversized Outboard Pillow Block Bearings
- Heavy Duty Construction
- Indexable Hawksbill –or– Zoidal Cutters US Patent
- Allen-Bradley Touch Screen Control
  - Ram Pressure and Motor Amperage controls
- Monorail Self Guiding Ram US Patent
- V-Belt Drive with Falk Gearbox
  - Single Nut Belt Tension Adjustment with Pre-Established Belt Alignment
  - Controlled Over-torque Limiting Clutch
- Reversible Counterknives
- Self-Cleaning Non-contaminating Rotor Seals
- Two-Speed Hydraulic Ram System
- Straight Walled Hopper - Customizable
- Removable Rear Compartment Access Covers
- Revision Controlled SolidWorks™ 3-D Design
- Warranty Statement
  - One Year Warranty on Manufacturing and Parts
  - Three Year Warranty on Falk Drive Train
  - Limited Lifetime Warranty on Forged Rotor

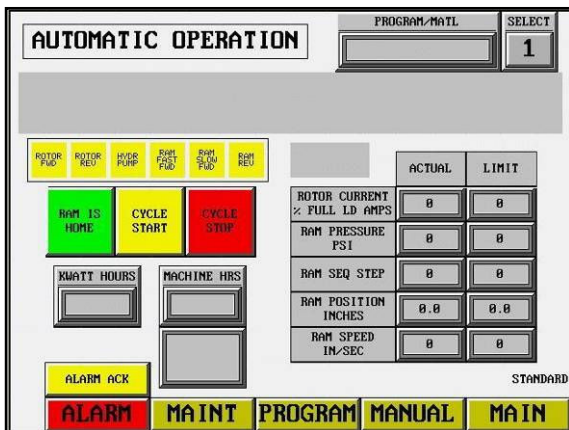

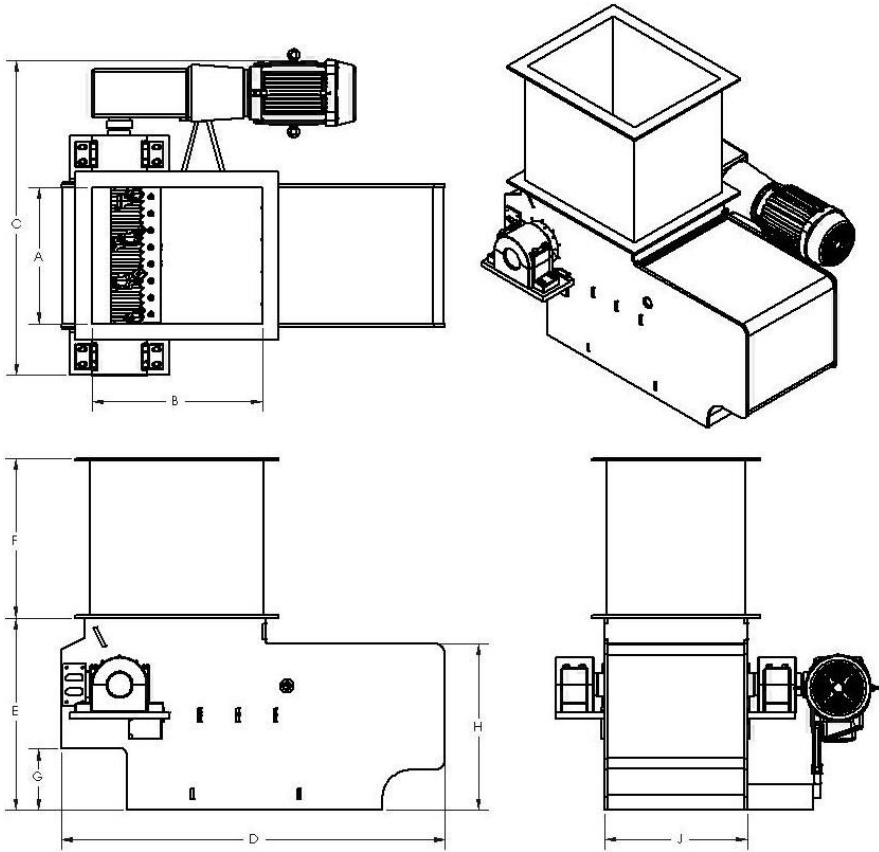

	25"	32"	42"
A	25.6	31.1	42.3
B	32.0	40.0	44.0
C	59.2	64.7	86.7
D	72.0	88.0	101.0
E	36.0		46.0
F	30.0		36.0
G	11.5		21.5
H	31.3		42.5
J	34.1	39.6	50.8

Specifications, appearances, and dimensions are subject to change without notice.

**Optional Features**

- Multiple Cutter Rows
- Belt Free Direct Drive Falk Gearbox
  - Controlled Over-torque Limiting Clutch
- Electric Soft Start and/or VFD Motor Control
- Electric Motor Fluid Coupling
- Ethernet Module for Remote PLC Access
- Corrugated Compartment Plate / Ram Top Plate
- Closed Loop Ram Velocity Speed Control
- Screens
  - Standard Round Hole 3/8" thru 4" Size
  - Triple-Cut Screen Providing Granulator Performance from a Shredder
  - Grooved Screen US Patent with Close Cutter Tolerance
- Water Cooled Rotor and Anvil
- Stainless Steel Machine Components
- Medical Waste Package
- Hoppers
  - Angled Hopper Walls
  - Fork Slot Hopper Openings
  - Automatic Cover for Product Containment

**Optional Auxiliary Components**

- Belt Infeed / Outfeed Systems
- Auger Outfeed Systems
- Shaker Table Infeed / Outfeed Systems
- Magnet Separators
- Metal Separation Equipment Gaylord Box Dumpers
- Outfeed Size Classification System
- Complete System Control Integration

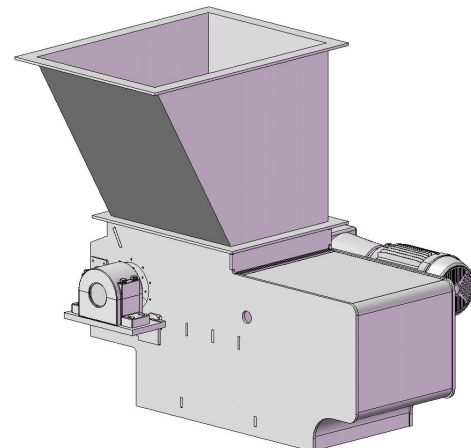

1000 W. Ormsby Ave. #25, Louisville, KY 40210  
Phone: (502) 637-6778 Fax (502) 637-6779

[www.republicmachine.com](http://www.republicmachine.com)  
[sales@republicmachine.com](mailto:sales@republicmachine.com)